

#THE SPIRITS BUSINESS

THE ONLY INTERNATIONAL TRADE MEDIA SOLELY DEDICATED TO SPIRITS



MEDIA PACK 2023

A NOTE FROM THE EDITOR

As the world's only international trade publication dedicated to spirits, *The Spirits Business* takes pride in bringing you only the highest-quality journalism



The digital age brings with it a mix of opportunities and challenges. News can be accessed at the click of a button – but that means misinformation can quickly spread.

As the world's only trade title dedicated to spirits, *The Spirits Business* is indisputably the must-read publication for the latest breaking news, in-depth analysis, executive interviews, data and opinions. Our team of talented journalists always go straight to the source, guaranteeing reliable news updates from around the globe.

From our monthly print magazine to our website (thespiritsbusiness.com), daily e-newsletter, social media platforms and app, *The Spirits Business* always has its finger on the pulse of this fast-moving industry. Our magazine delves deep into individual spirits categories and markets, while our Back Bar section contains insightful features about the on-trade.

As you'll find in our 2023 features list, we look at established categories, including vodka, gin and Cognac, alongside disruptive, up-and-coming drinks such as alternative agave-based spirits and hard seltzers.

Plus, we offer a number of in-depth reports throughout the year to give additional insight into the trade. These include the *Global Travel Retail Report*, *World Spirits Report*, and *Global Bar Report*.

Most notably, our *Brand Champions* report, compiled in-house by our team of journalists, tells you all you need to know about the world's biggest-selling, million-case brands.

In addition, our experienced events team strives to reward the best of the spirits world through The Global Spirits Masters Competitions, a blind-tasting series judged by independent experts – unique in the industry.

Ultimately, *The Spirits Business* is passionate about all things spirits and is fully immersed in the trade. We look forward to supporting our media partners to reach their goals in the coming year and beyond.

MELITA KIELY

Editor

The Spirits Business



PRINT READERSHIP & CIRCULATION

The Spirits Business is the only international trade magazine and website in the world that is dedicated to spirits. The circulation of both print and digital copies is up to 13,000 copies per month across 120 countries, reaching more than 50,000 spirits professionals worldwide.

Readership

Our global audience comprises the biggest retailers, distributors, wholesalers and duty free buyers in the business. Furthermore, *The Spirits Business* reaches thousands of world-class bartenders and bar owners around the globe.

Bonus distribution

In addition to our regular subscribers, we are also distributed at all the major trade shows and events:

- Prowein, Düsseldorf
- IAADFS Duty Free & Travel Retail Summit of the Americas
- TFWA Asia Pacific Exhibition & Conference
- Vinexpo Paris
- Tales of the Cocktail
- Bar Convent Brooklyn
- Bar Convent Berlin
- TFWA World Exhibition & Conference
- London Cocktail Week

Furthermore, our media partners also benefit from additional distribution at our in-house event, The Wine & Spirits Show.

Union Press, Fourth Floor, Wigglesworth House, 69 Southwark Bridge Road, London SE1 9HH
 Tel: +44 (0)20 7803 2420
 web: www.thespiritsbusiness.com

Readership

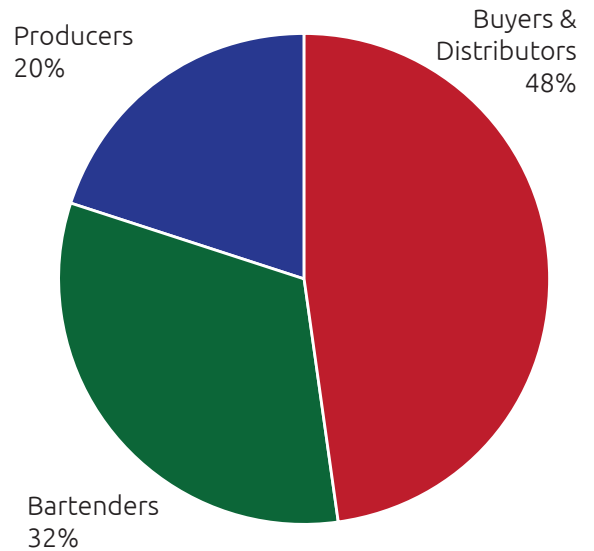

Top 15 countries

- | | | |
|--------|----------|--------------|
| UK | Germany | South Africa |
| France | Ireland | Argentina |
| US | Chile | Mexico |
| Italy | Canada | Netherlands |
| Spain | China/HK | Russia |

THE SPIRITS BUSINESS

WEB & SOCIAL.

Updated daily with relevant and timely news, interviews and features from the global drinks industry, *thespiritsbusiness.com* is viewed by around 452,000 unique users each month.

With numerous display and sponsorship opportunities across both our websites and newsletters, brands can access a cost-effective platform with *The Spirits Business* to target our expanding global online readership.

In addition, we reach and influence thousands of followers every day via social media. Whether it is Twitter, Instagram, Facebook or LinkedIn, we are constantly engaged with key industry figures and consumers.

Top 15 countries

- | | | | | |
|-------|-----------|--------------|-------------|-----------|
| US | Canada | France | Netherlands | Italy |
| UK | Australia | Germany | Spain | Singapore |
| India | Ireland | South Africa | Mexico | Sweden |

Monthly stats:

Unique users: 452,000
Visits from more than 217 countries

Social media channels:

Twitter: 29.3k followers
Facebook: 21k followers; 19k page likes
Instagram: 13k followers; 150 likes per post
LinkedIn: 77k followers

Close to 20,000 people subscribe to our daily newsletter, which gives you the chance to advertise to a global digital audience.

FEATURES LIST

As the must-read publication for the international spirits trade, our 2023 features list is more varied than ever before. Spanning established categories such as Scotch, gin and vodka to up-and-coming disruptive sectors, plus numerous global reports, our schedule will help you plan your most effective marketing strategy yet.

Month	Features	Awards results	Additional distribution	Editorial deadline
January	Most Innovative Spirits list Spirits trends to watch Category reports: Australian whisky; RTDs	Low & No Masters; Grand & Taste Masters 2022		12 December
February	The Tequila issue Category reports: Tequila; Mezcal; Low/no-alcohol Regional report: UK Gin in travel retail Vinexpo Paris preview	Tequila & Mezcal Masters	Vinexpo Paris	16 January
March	The Rum issue Category reports: Rum; Third-party spirits; Pisco Regional report: South Africa IAADFS Summit of the Americas preview; Prowein preview	Rum & Cachaça Masters	IAADFS Summit of the Americas; Prowein, Düsseldorf	17 February
April	The Vodka issue Category reports: Vodka; Tonics and mixers; Apéritifs Regional report: Eastern Europe Vodka in travel retail	DB & SB Spring Blind Tasting; Tonic & Mixer Masters		17 March
May	The Asia issue Category reports: Asian spirits; Cognac; Brandy Regional report: South Korea Irish whiskey in travel retail	Cognac Masters; Brandy Masters; Asian Spirits Masters	London Wine Fair	17 April
June	The Brand Champions 2023* Category reports: Rum; Hard Seltzers Regional report: Western Europe Tequila in travel retail	Scotch Masters; Hard Seltzer Masters	Bar Convent Brooklyn	15 May
July	The Gin issue Category reports: Gin; Sustainability; Alternative agave-based spirits Regional report: US Tales of the Cocktail preview	Gin Masters – First Tasting	Tales of the Cocktail	16 June
August	The Whisky issue Category reports: Scotch whisky; World whisky; Rye whisky; Spirits packaging Regional report: Canada	American Whiskey, Irish Whiskey, and World Whisky Masters; Cocktail & Signature Serve Masters		14 July
September	The Travel Retail issue Global travel retail report Category reports: Irish whiskey; Vodka; Limoncello Show previews: TFWA World Exhibition & Conference	Vodka Masters; Travel Retail Masters	TFWA World Exhibition & Conference	18 August
October	The Luxury Spirits issue Category reports: Luxury spirits; Japanese whisky; Low/no-alcohol Regional report: Nordics Show previews: Bar Convent Berlin; London Cocktail Week; The Wine & Spirits Show	Luxury Masters; DB & SB Autumn Blind Tasting	Bar Convent Berlin; London Cocktail Week; The Wine & Spirits Show	15 September
November	The On-Trade issue Global Bar Report Category reports: Liqueurs; Tonics & mixers; Cocktail bitters; American whiskey	Liqueur Masters; Speciality Masters; Pre- Mixed & RTD Masters		16 October
December	World Spirits Report Category reports: Aquavit; Sustainability; Gin Rum in travel retail	Design & Packaging Masters; SB Awards; Gin Masters – Second Tasting	The Global Spirits Masters Competitions Awards Lunch	17 November

* The definitive guide to spirits brands selling more than one million nine-litre cases per annum. The Brand Champions series will contain exclusive and comprehensive data on spirits brands' sales volumes, equipping industry professionals with unparalleled information relevant to this dynamic industry.



THE GLOBAL SPIRITS MASTERS COMPETITIONS 2023

Launched in 2008, The Global Spirits Masters Competitions rates and rewards excellence in spirits production, giving brands key differentiation in a crowded market.

Judging is divided into 22 separate competitions to ensure each spirit category is given the utmost attention by specialist judges.

The Global Spirits Masters Competitions is unique in its exclusive use of completely independent expert judges, including journalists, retail buyers, bartenders and educators. As such, entrants can rest assured that their product has been assessed constructively and without bias by our panels of professionals. Judges can award Silver, Gold and Master medals, as well as additional awards and trophies for outstanding excellence.

The Global Spirits Masters Competitions 2023

Masters	Entry deadline	Sample deadline	Judging	Results published
Low & No-Alcohol	28 November 2022	2 December 2022	December 2022	January 2023
Tequila & Mezcal	1 January 2023	7 January 2023	January 2023	February 2023
Rum & Cachaça	24 January 2023	30 January 2023	February 2023	March 2023
Tonic & Mixer	22 February 2023	28 February 2023	March 2023	April 2023
Asian Spirits	22 March 2023	29 March 2023	April 2023	May 2023
Cognac	25 March 2023	2 April 2023	April 2023	May 2023
Brandy	26 March 2023	3 April 2023	April 2023	May 2023
Hard Seltzer	20 April 2023	27 April 2023	May 2023	June 2023
Scotch Whisky	20 April 2023	27 April 2023	May 2023	June 2023
Gin (First Tasting)	18 May 2023	26 May 2023	June 2023	July 2023
American Whiskey	20 June 2023	28 June 2023	July 2023	August 2023
Irish Whiskey	20 June 2023	28 June 2023	July 2023	August 2023
World Whisky	20 June 2023	28 June 2023	July 2023	August 2023
Cocktails & Signature Serves	21 June 2023	29 June 2023	July 2023	August 2023
Vodka	22 July 2023	28 July 2023	August 2023	September 2023
Travel Retail	25 July 2023	1 August 2023	August 2023	September 2023
Luxury	23 August 2023	1 September 2023	September 2023	October 2023
Liqueur Masters	18 September 2023	27 September 2023	October 2023	November 2023
Speciality	18 September 2023	27 September 2023	October 2023	November 2023
Pre-Mixed & RTD	18 September 2023	27 September 2023	October 2023	November 2023
Gin (Second Tasting)	20 October 2023	30 October 2023	November 2023	November 2023
Design & Packaging	24 October 2023	1 November 2023	November 2023	December 2023

Further competitions and awards by *The Spirits Business*

The Spirits Business Awards 2023

SB Awards	30 July 2023	10 August 2023	August 2023	October 2023
-----------	--------------	----------------	-------------	--------------

The Drinks Business & The Spirits Business Blind Tastings 2023

DB & SB Spring Tasting	5 February 2023	10 February 2023	February 2023	April 2023
DB & SB Autumn Tasting	26 August 2023	1 September 2023	September 2023	October 2023

The Alan Lodge Young International Drinks Writer of the Year Award

The Alan Lodge Award 2023	30 July 2023	10 August 2023	October 2023
---------------------------	--------------	----------------	--------------



EVENTS

The Spirits Business has a thriving events portfolio, which builds on our series of internationally recognised blind-tasting competitions, including consumer and trade events.

For example, our annual party to celebrate the winners of The Travel Retail Masters is held at the TFWA World Exhibition & Conference in Cannes, and we also welcome medal winners to celebrate their successes at The Global Spirits Masters Competitions Awards Lunch, which is held in London.

Events schedule

***The Spirits Business'* Travel Retail Beach Party – October 2023**

Taking place during The TFWA Exhibition & Conference in Cannes, *The Spirits Business'* Travel Retail Beach Party will celebrate the winners from The Vodka Masters and The Travel Retail Masters 2022 during an evening of cocktails and canapés at an exclusive beach bar venue.

The SB Awards Ceremony 2023 – November 2023

Celebrating the highest achievements across Retail & Tourism, Sustainability & Innovation, Culture & Tourism, Product & Personality in the spirits industry, The SB Awards Ceremony will see representatives from the brands making waves in the market come together for the announcement of this year's category champions.

The Wine & Spirits Show – October 2023

Run in partnership with *the drinks business*, *The Spirits Business* will co-host The Wine & Spirits Show, showcasing the best wines and spirits on the market in a two-day trade and consumer event. Taking place in London, our show will see more than 2,000 guests enjoy a range of products from exhibitors, medal-winning spirits from The Global Spirits Masters Competitions, and G&Ts from our gin partners and official tonic sponsor.

The Global Spirits Masters Competitions Awards Lunch – December 2023

The Spirits Business and The Global Spirits Masters Competitions teams will come together to host the annual Awards Lunch this December where the personalities behind the medal-winning brands from The Global Spirits Masters Competitions 2023 will be invited to collect their awards and enjoy an afternoon of celebration in a central London venue.

Technical specifications for THE SPIRITS BUSINESS

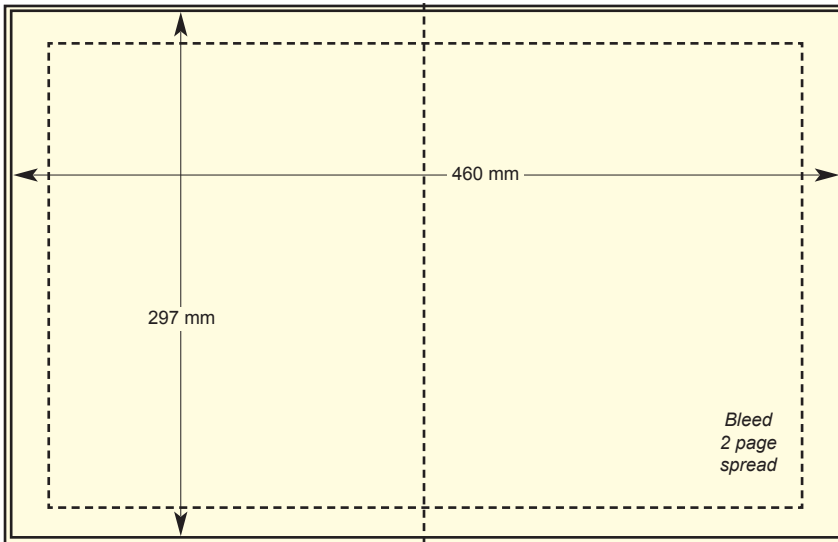

Double Page Spread

Bleed: 303 mm x 466 mm
Trim: 297 mm x 460 mm

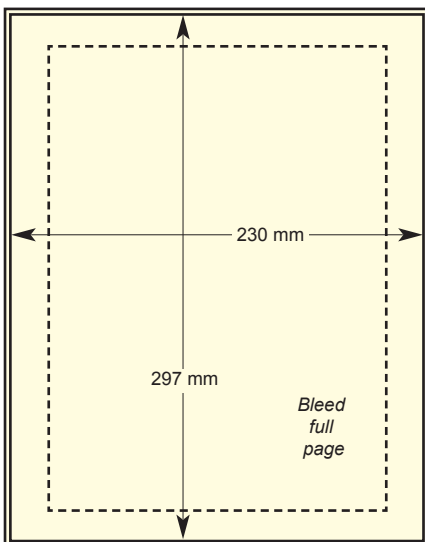

PERFECT BINDING:

Please be aware that all of our magazines are perfect bound. It is the designer's responsibility to include double gutter image allowance if it is required. Also, we recommend that no type, logo or any important matter should appear within 8mm either side of the gutter on any spread to avoid being obscured.

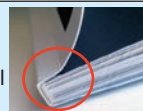

Full Page

Bleed: 303 mm x 236 mm
Trim: 297 mm x 230 mm

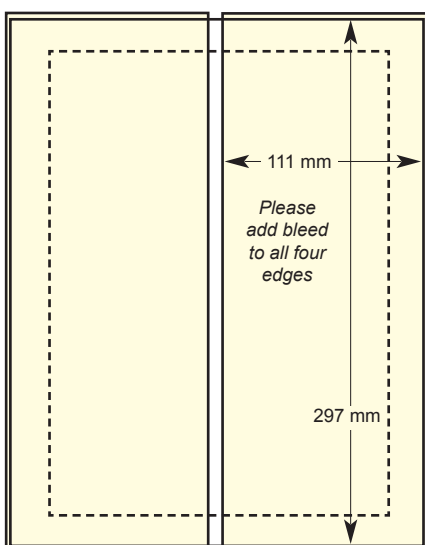

Half Page Vertical

Bleed: 303 mm x 118 mm
Trim: 297 mm x 112 mm

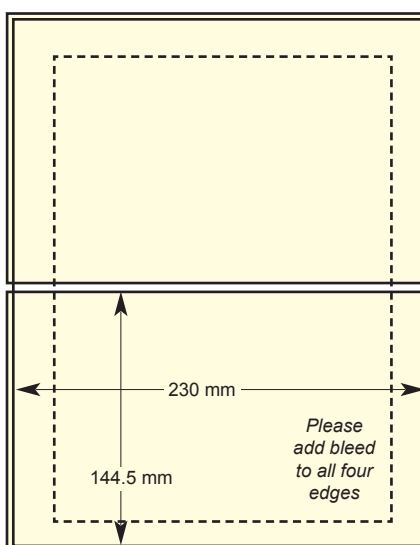

Half Page Horizontal

Bleed: 151 mm x 236 mm
Trim: 145 mm x 230 mm

COPY REQUIREMENTS

We require that all copy be supplied only in digital format, and as specified below.

ACCEPTABLE FORMATS:

- **Print Optimised (high resolution) PDF to PDF/X-1a:2001 standard, otherwise,**
- **High-resolution CMYK flat bitmap file (eg TIFF, PSD or JPG format)**
- Please always include crop marks and 3mm of bleed on ALL FOUR EDGES
- Max ink coverage = less than 290%
- If you use ICC profiles, please set your output to FOGRA39 (ISO 12647-2:2004)
- Please do **NOT** send us live files such as InDesign, Illustrator or Quark documents

IMPORTANT: All artwork must be converted to CMYK before sending. In all instances where colour fidelity is critical, a certified colour match is required two weeks prior to printing.

DELIVERY to the Production Dept:

For files up to 25Mb (approx) in size

- Send your PDF file/s by email to: production@unionpress.co.uk

For files over 25Mb in size:

- We would recommend use of one of the free-of-charge online services such as **wetransfer, hightail, sendspace, dropbox** or any other such similar site.

We will check and preflight supplied files against our standard print profiles and return a summary acknowledgement of receipt and suitability for use. If problems are found in any files we will contact the sending party to make amendments.

PRODUCTION CONTACT: Mile Budimir | direct: +44 (0)20 7803 2456 | mobile: +44 (0)7388 876515 | email: production@unionpress.co.uk

Technical specifications for THE SPIRITS BUSINESS

PLEASE REMEMBER TO SEND A LINK WITH YOUR ARTWORK – AT LEAST HALF OF ALL BANNERS ARE SUBMITTED WITHOUT ONE AND IT IS, BY FAR, OUR MOST COMMON REASON FOR DELAY...

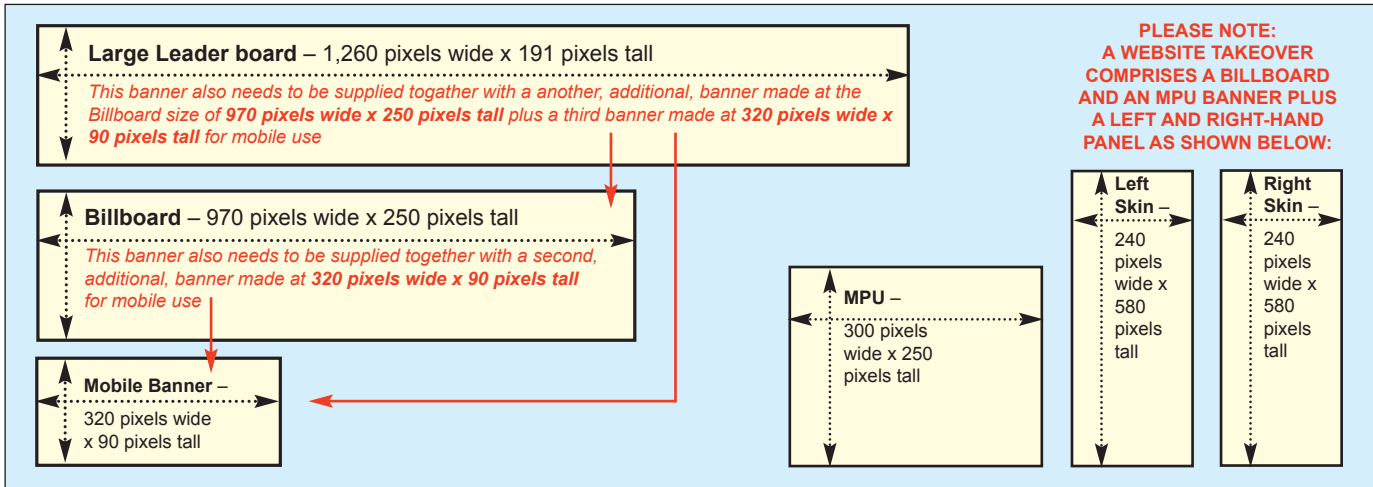

ONLINE ADVERTISING SPECIFICATIONS:

WEBSITE BANNERS AND BUTTONS:

Banner Description	Dimensions (width x height)	Maximum file size	Acceptable file types & technical notes <i>(Please note Flash-based adverts are no longer supported anywhere)</i>
Large Leaderboard *	1,260 pixels x 191 pixels	200Kb	JPG, PNG, GIF, HTML5**, Third-party tag <i>(see sizing note below)</i>
Billboard *	970 pixels x 250 pixels	200Kb	JPG, PNG, GIF, HTML5**, Third-party tag <i>(see sizing note below)</i>
MPU (Mid Page Unit)	300 pixels x 250 pixels	200Kb	JPG, PNG, GIF, HTML5**, Third-party tag
Button	150 x 150 pixels	200Kb	JPG, PNG, GIF
Mobile	320 pixels x 90 pixels	200Kb	JPG, PNG, GIF, HTML5**, Third-party tag

Site Takeover A site takeover is a combination position that includes a **Billboard**, **MPU** and **TWO side panels** that will follow the viewers progress up and down the page. As a result, we need to get hold of the following sizes of artwork:
 1 x **Billboard**: 970 pixel wide x 250 pixel tall + an additional 320 pixel wide x 90 pixel tall mobile version
 1 x **MPU**: 300 pixel wide x 250 pixel tall
 2 x **Side panels**: 240 pixel wide x 580 pixel tall (left-hand side) + 240 pixel wide x 580 pixel tall (right-hand side)

PLEASE NOTE:

* **Large Leaderboard & Billboard banner positions** need to be supplied together with additional banners in order to work. When supplying artwork for the **Large Leaderboard** we need **THREE banners** – made at **1,260 x 191 pixels**, **970 x 250 pixels** and **320 x 90 pixels**. When supplying artwork for the **Billboard** we need **TWO banners** banners – made at **970 x 250 pixels** and **320 x 90 pixels**.

** **HTML5** can be supplied as third-party tag, DoubleClick Studio creative, DCM tag or as self-contained HTML5 in a single-code snippet. Where artwork is run as HTML, we would request that you respect our audience experience and refrain from using pop ups, pop unders, ad pushdown or any above page, floating or between layer windows. Audio and video can be used in banner as a third-party tag streaming from your video provider with stop, pause, play and audio control buttons required. HTML banners should not exceed 15 file requests during initial file load and host-initiated subload and all files for the banner (.html, .js, .css, images, etc.) must be included as part of the maximum file weight calculation for all file load limits.

NEWSLETTER BANNERS AND BUTTONS:

Banner Description	Dimensions (width x height)	Maximum file size	Acceptable file types
Main Body Banner	632 pixels x 90 pixels	200Kb	JPG, PNG, GIF
Button	150 x 150 pixels	200Kb	JPG, PNG, GIF

PLEASE NOTE:

It is not possible to run or embed assets that require server-side technologies within an email newsletter; we only support static files in JPG and PNG format and animations in GIF format. Furthermore, please be aware that certain email clients deliberately stop GIF animations for security reasons (eg, some versions of Microsoft Outlook) and only show a static image (for more explanation: <https://support.microsoft.com/en-us/office/the-animated-graphic-in-my-e-mail-message-doesn-t-work-a5e8a2a3-9d86-4203-8920-c88cb8739e34>) as a result we would recommend keeping all of the most important information in the first frame of your animation.

ARTWORK DELIVERY:

Please submit your completed artwork to: **production@unionpress.co.uk** for initial checking and pre-approval. On completion we will return a summary acknowledgement of receipt and suitability for use. However, if problems are found in the supplied files we will contact the sending party to make them aware of the issue and may suggest amendments. We will always do our best to ensure that artwork will work across all browsers and platforms, but cannot make any guarantees in material supplied to us.

PRODUCTION CONTACT: Mile Budimir | direct: +44 (0)20 7803 2456 | mobile: +44 (0)7388 876515 | email: production@unionpress.co.uk

CONTACT US

Richard Cochrane

Managing Director
Tel: +44 (0) 207 803 2449
Mob: +44 (0) 7887 606866
Email: richard.cochrane@thespiritsbusiness.com

Ryan Graves

Sales Director
Tel: +44 (0) 207 803 2424
Mob: +44 (0) 7527 362 471
Email: ryan.graves@thespiritsbusiness.com

Anthon Linton

Sales Manager
Tel: +44 (0) 207 803 2422
Mob: +44 (0) 7552 922 603
Email: anthon.linton@thespiritsbusiness.com

Melita Kiely

Editor
Tel: +44 (0) 207 803 2436
Email: melita.kiely@thespiritsbusiness.com

Nicola Carruthers

Deputy Editor
Tel: +44 (0) 207 803 2444
Email: nicola.carruthers@thespiritsbusiness.com

Georgie Collins

Digital Editor
Tel: +44 (0) 207 803 2433
Email: georgie.collins@thespiritsbusiness.com

Alice Brooker

Senior Staff Writer
Tel: +44 (0) 207 803 2425
Email: alice.brooker@thespiritsbusiness.com

Rhiannon Morris

Sales & Marketing Manager
Tel: +44 (0) 207 803 2430
Email: rhiannon.morris@thespiritsbusiness.com

Christelle Monges

Sales & Marketing Executive
Tel: +44 (0) 207 803 2420
Email: christelle.monges@thespiritsbusiness.com

Sophie Allan

Events Director
Tel: +44 (0) 207 803 2442
Email: sophie.allan@thespiritsbusiness.com